

NR	CN NR	MODIFICATION	DATE	SIGN
----	-------	--------------	------	------

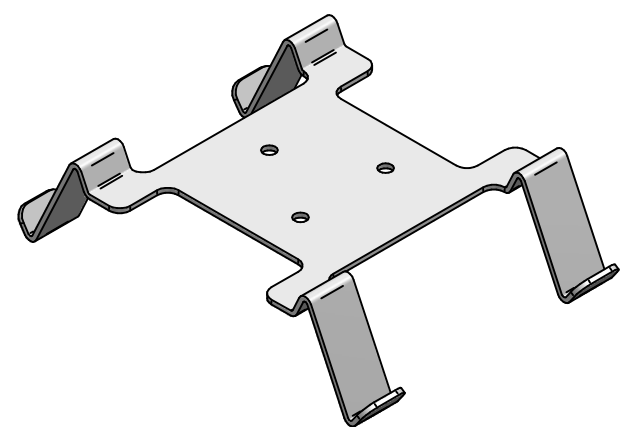
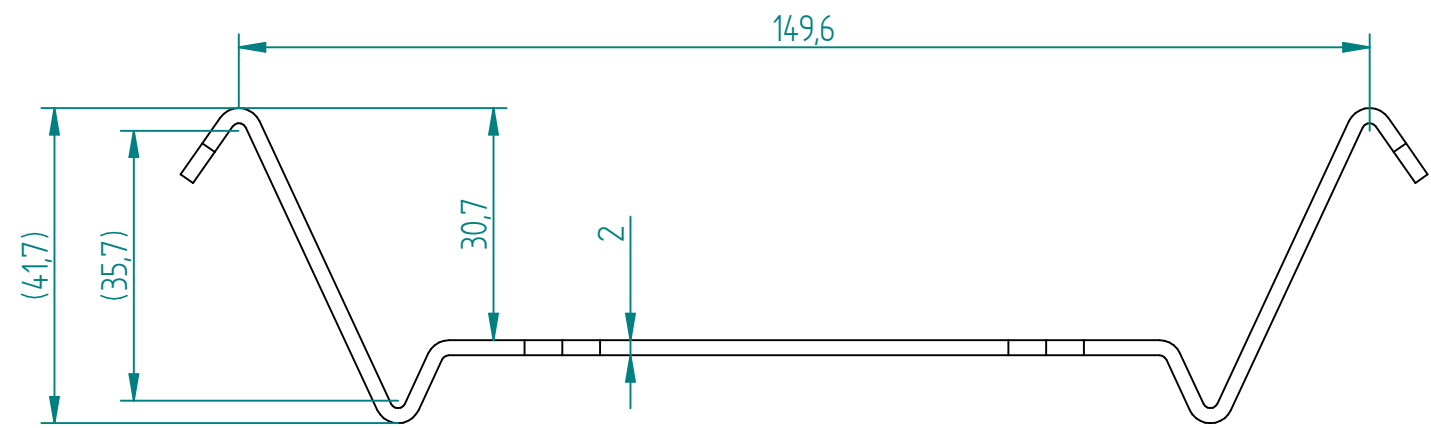
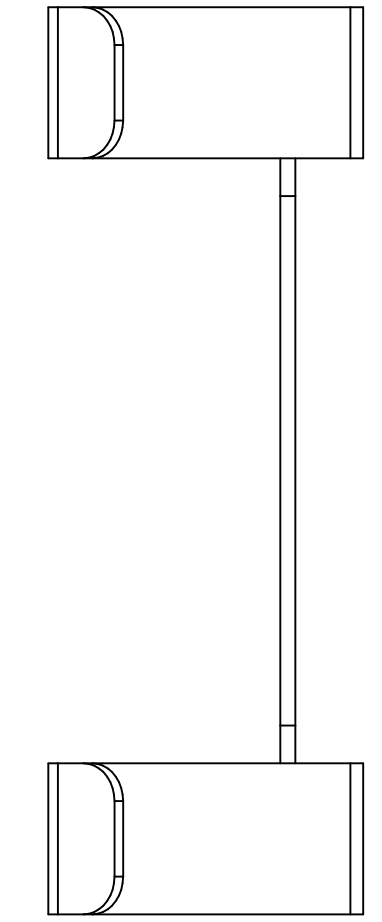
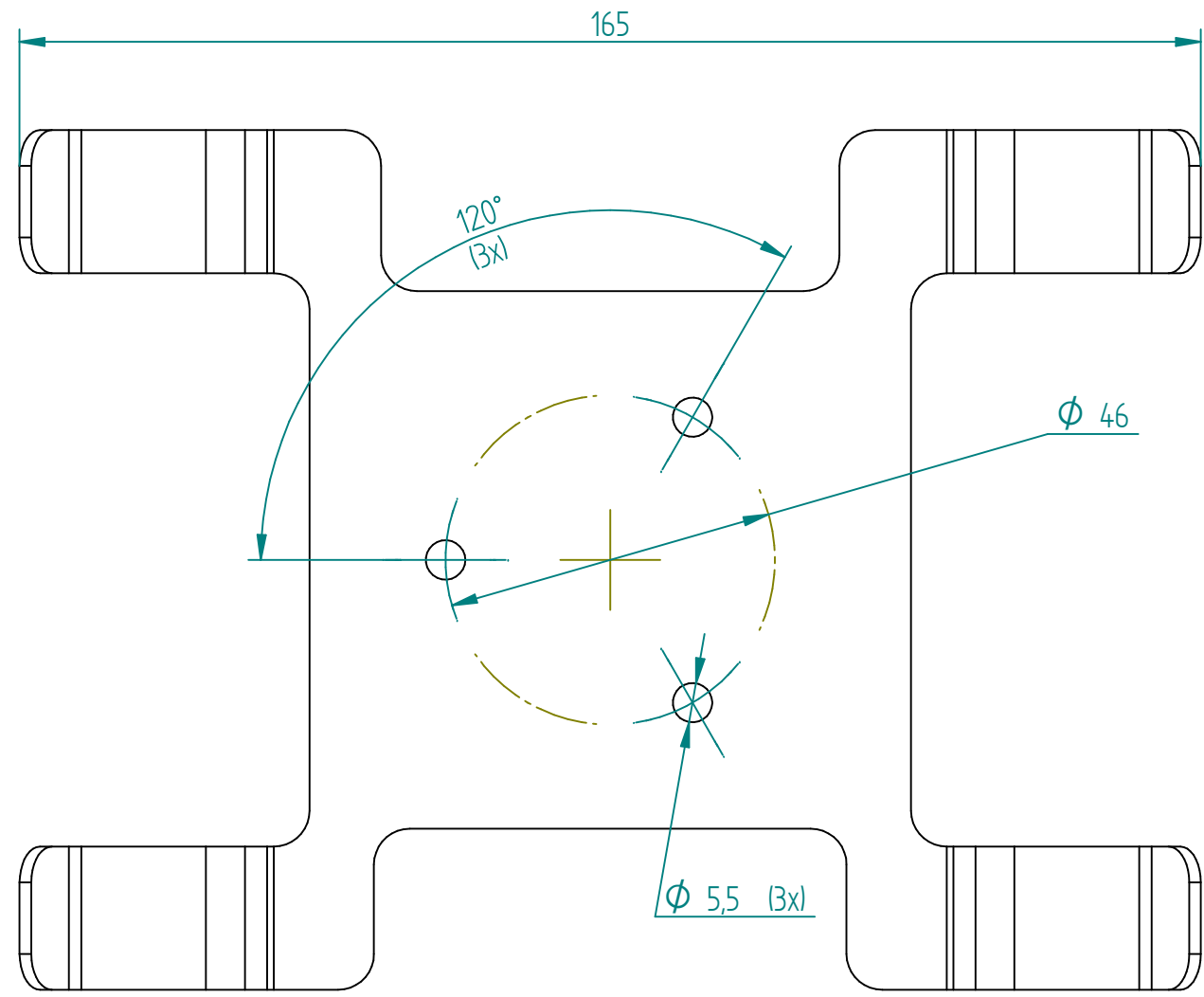

Solid 3-D cad model is made nominal without tolerances.
 Form tolerance  unless otherwise stated.

Model file name: C000 157-86rPa3.stp

Unbend geometri according to C000 157-86rPa3.dxf

Stainless steel plate 2331-14		-	Passivated ISO 16048
MATERIAL		DIMENSION	SURFACE TREATMENT
GENERAL TOLERANCE		GENERAL SURFACE FINISH Ra	RoHS 2 COMPLIANT, DIRECTIVE 2011/65/EU
SS-ISO 2768-1 c		-	Yes
CHECKED FRR	APPROVED PFG	NAME	PRODUCT
DRAWN TWL	DATE 2023-09-25	Mounting bracket	CCPilot V710
DRAWING NO C000 157-86			SHEET 1 (2)
crosscontrol crosscontrol.com			REVISION Pa3

THIS DRAWING IS THE PROPERTY OF CROSSCONTROL. PROTECTED IN ACCORDANCE WITH PREVAILING LAW.

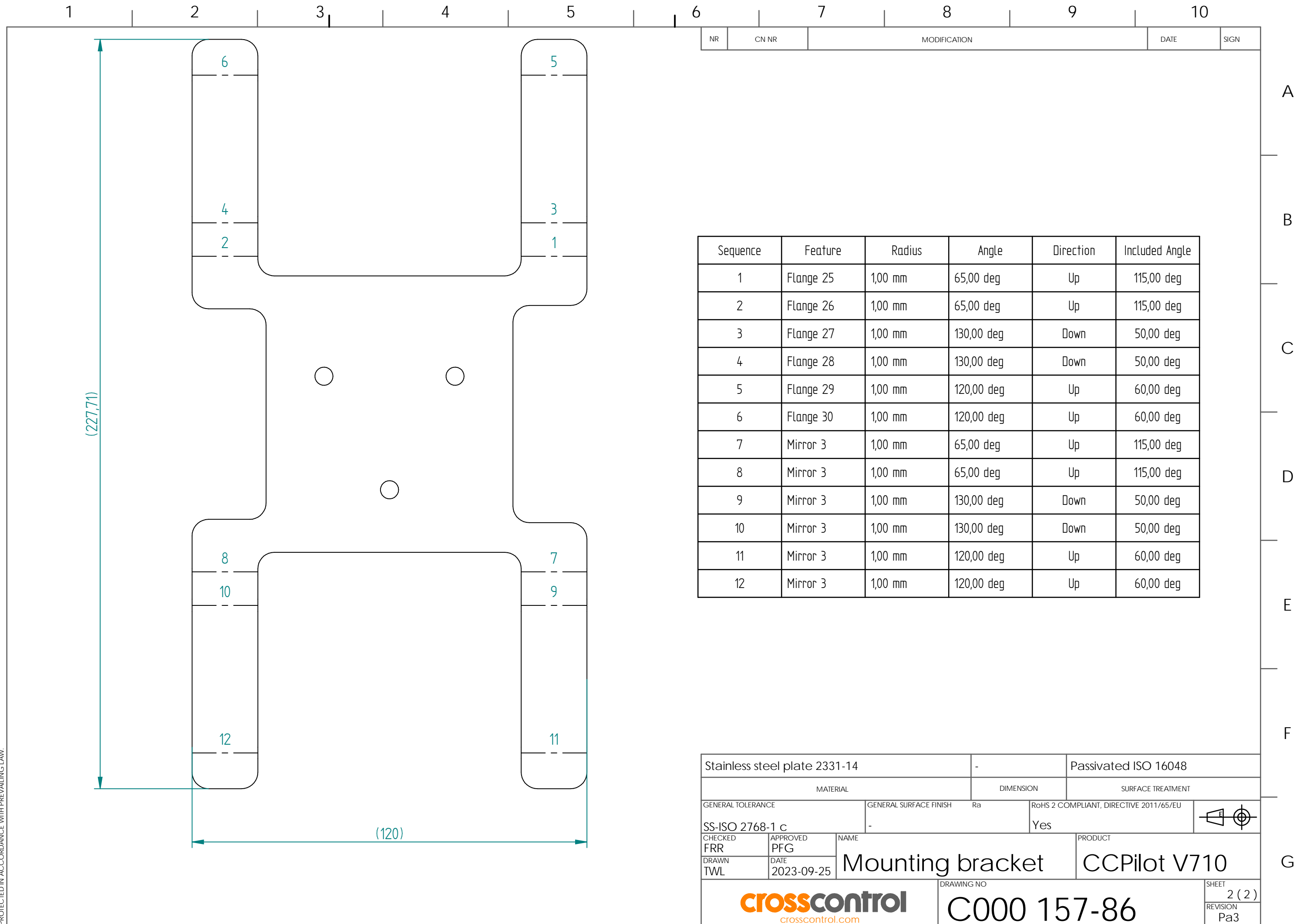

NR	CN NR	MODIFICATION	DATE	SIGN
----	-------	--------------	------	------

Sequence	Feature	Radius	Angle	Direction	Included Angle
1	Flange 25	1,00 mm	65,00 deg	Up	115,00 deg
2	Flange 26	1,00 mm	65,00 deg	Up	115,00 deg
3	Flange 27	1,00 mm	130,00 deg	Down	50,00 deg
4	Flange 28	1,00 mm	130,00 deg	Down	50,00 deg
5	Flange 29	1,00 mm	120,00 deg	Up	60,00 deg
6	Flange 30	1,00 mm	120,00 deg	Up	60,00 deg
7	Mirror 3	1,00 mm	65,00 deg	Up	115,00 deg
8	Mirror 3	1,00 mm	65,00 deg	Up	115,00 deg
9	Mirror 3	1,00 mm	130,00 deg	Down	50,00 deg
10	Mirror 3	1,00 mm	130,00 deg	Down	50,00 deg
11	Mirror 3	1,00 mm	120,00 deg	Up	60,00 deg
12	Mirror 3	1,00 mm	120,00 deg	Up	60,00 deg

Stainless steel plate 2331-14		-	Passivated ISO 16048	
MATERIAL		DIMENSION	SURFACE TREATMENT	
GENERAL TOLERANCE		GENERAL SURFACE FINISH Ra	RoHS 2 COMPLIANT, DIRECTIVE 2011/65/EU	
SS-ISO 2768-1 c		-	Yes	
CHECKED FRR	APPROVED PFG	NAME	PRODUCT	
DRAWN TWL	DATE 2023-09-25	Mounting bracket	CCPilot V710	
DRAWING NO		SHEET		REVISION
C000 157-86		2 (2)		Pa3



C000 157-86